



Zhaga

Consortium
for the
standardization of
LED light engines

The vision

version 20100123



Mission

- LED lighting serves the lighting market by better and more efficient lighting solutions
- Zhaga promotes the growth of the application of LEDs in the market of general illumination by
 - defining stable design platforms for luminaire makers by standardization of interfaces for these light engines
 - preventing fragmentation into a large number of incompatible light engines
 - enabling second source supply of LED light engines
 - stimulating market growth by fostering competition
- Reducing development cost of lighting applications
- Creating confidence in the market



LED light engines

- An LED light engine is an **LED module with defined interfaces** that do not depend on the type of LED technology used inside the light engine.
- Defined interfaces make it possible for light engine manufacturers to supply a light engine during many years while being free to improve internals of light engines

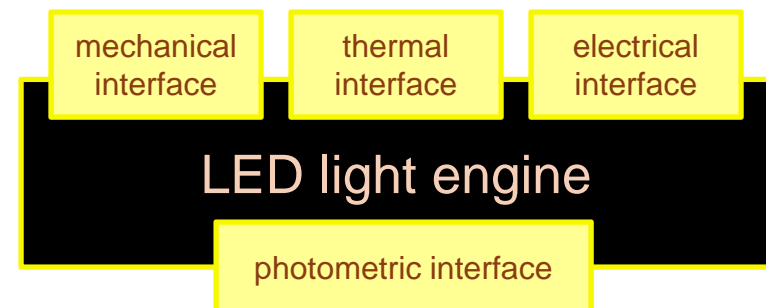



Zhaga

- Zhaga is a *consortium of industry players* that creates
 - Standardised interfaces for LED Light engines to secure a stable design platform for luminaire designers and manufacturers
- Zhaga is an *industry-wide* co-operation:
 - LED light engine manufacturers
 - LED luminaire manufacturers
 - Components additionally necessary (heat sinks, optics....)
- Zhaga is an *open* co-operation
 - open to any company that subscribes to the vision/mission and is willing to contribute to the success
- Zhaga is a *global* co-operation
 - Zhaga is a co-operation of companies from all regions
 - Zhaga will set global standards





Speed

- Zhaga will move fast.
 - The industry needs light engine standards **now**.
- Zhaga will establish its standards first as an industry standard
- Zhaga will offer the finished standards to an SDO*, such as IEC, for formal standardization.

* Standard Development Organization



Organization

- Steering Group
 - Consists of all active members when the number of members is small. Will be elected by the members when the number of members becomes large
 - Determines the rules, regulations and recommends new members
 - Takes the initiative to start, or stop, work on new light engine standards
 - Defines the assignment (charter) of work groups
 - Appoints chair, and vice-chair persons of work groups
 - Approves standards created by work groups

- Work Groups
 - Technical Coordination Work Group
 - responsible for consistency between deliverables of all technical work groups
 - Promotion Work Group
 - takes care of Zhaga web site, press contacts, newsletters, etc.



Stable interfaces – Rapid innovation

- The consortium will standardize *only* what is necessary to enable the interchangeability of light engines from different manufacturers or of different light engine versions of the same supplier
- As a result the design freedom inside the light engines and in the luminaires is maximized.
- The consortium promotes the continued rapid innovation in LED lighting technology inside the light engine

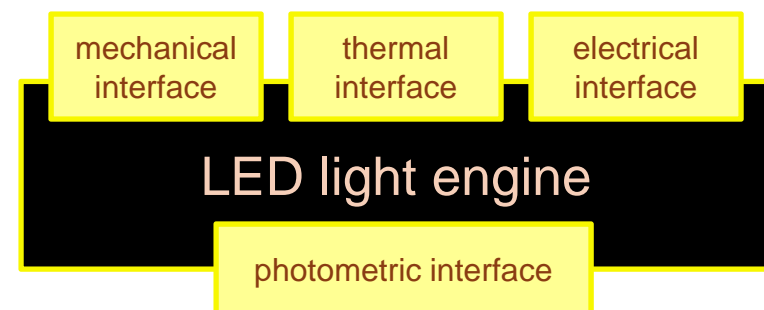



A family of standards

- The consortium will standardize interfaces of many different light engines
 - Different applications need different light engines
 - Advancement in LED technology expected to gradually enable smaller light engines with the same lumen output and smaller heat sinks
- Connectors, control interfaces, photometric interfaces, and other interfaces will be reused across light engine standards.
 - Arbitrary variations will be avoided.
 - Existing standards will be used whenever possible (DALI, for example, or the 0-10V dimming control)
- Where practically possible, the choice of interface variants will be based on light engines that are already on the market



Zhaga defines a family of interchangeable light engines with many variants

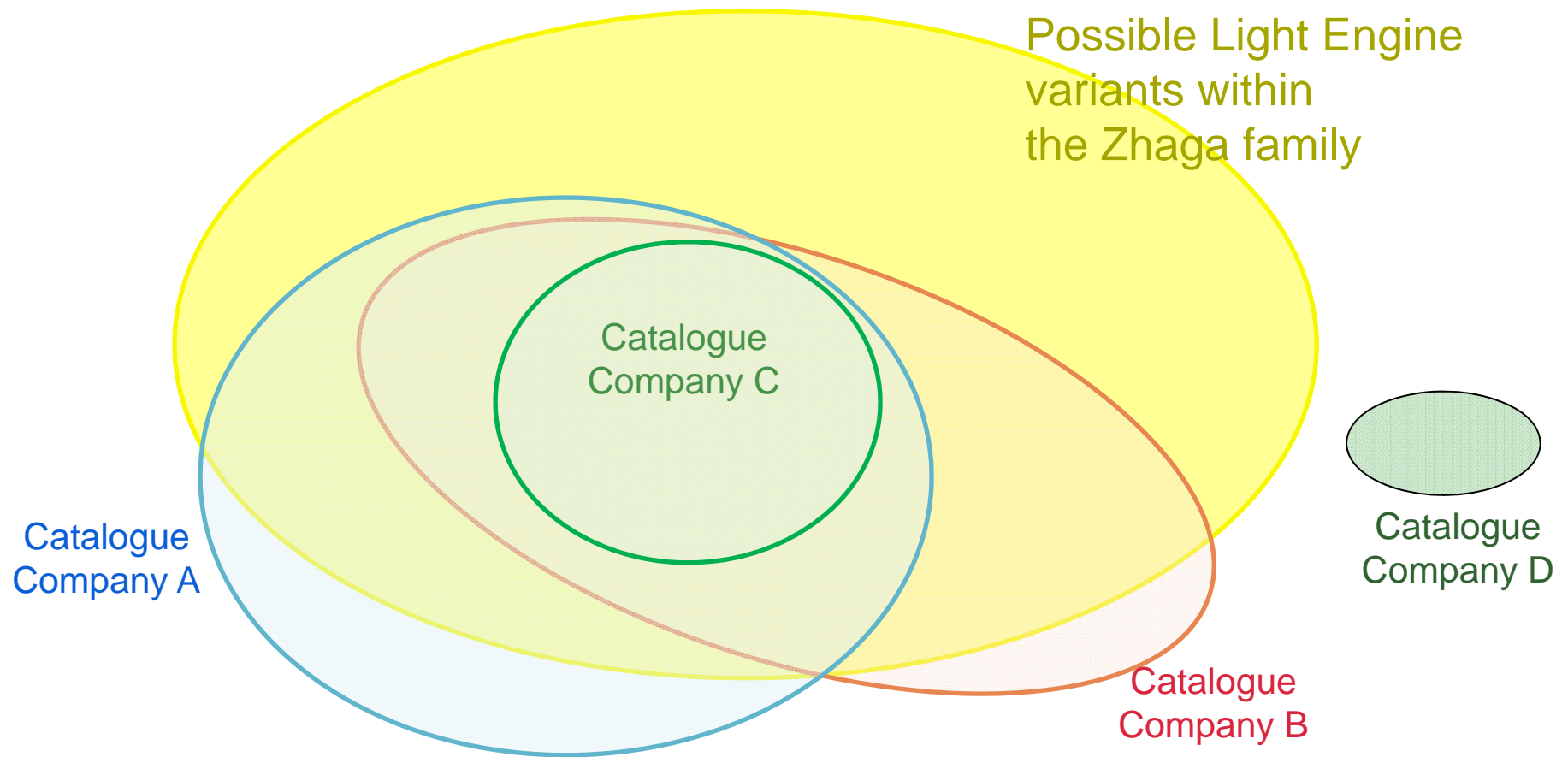



Zhaga will focus on interoperability through interface standardization, not on performance specification

Int'l Standardization organizations
Consortium: Zhaga

- interchangeability-aspects
- interface standards
- measurements methods

Governments
Quality label organizations
Voluntary industry agreements

Companies

- product specifications
- data sheet

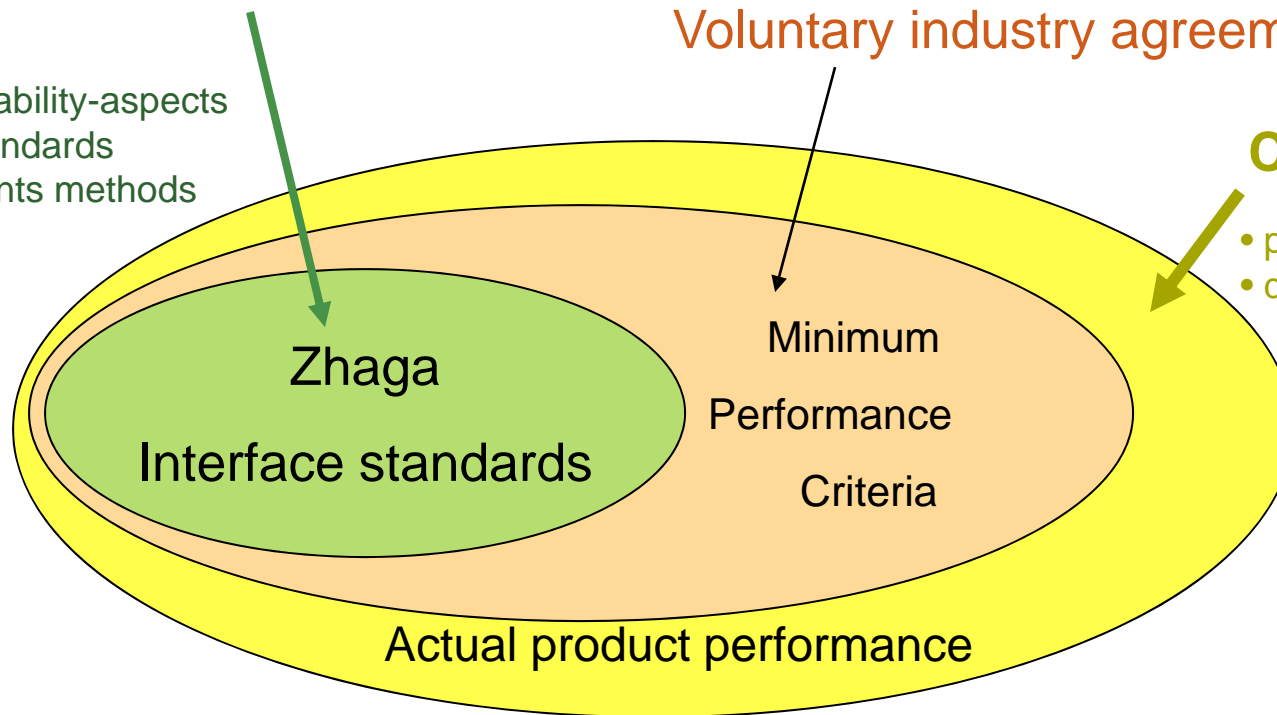



The 5 interfaces

1. Dimensional / Mechanical (incl. “socket”)
2. Power, insulation, earth
3. Controls
4. Photometric (lumen output, colour, light distribution)
5. Thermal

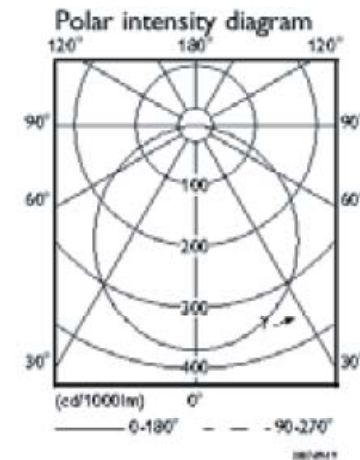
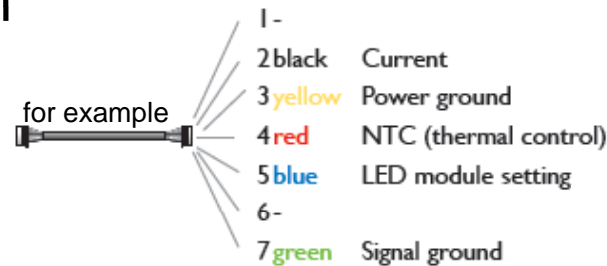
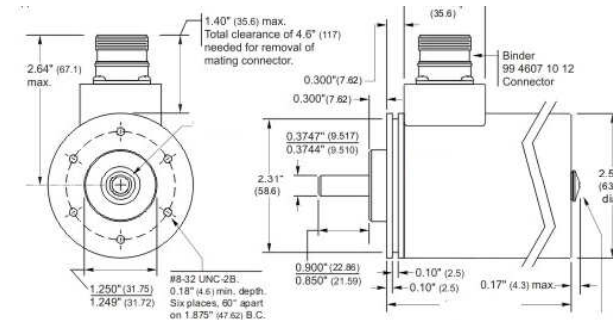



Maximum design freedom **inside** and **outside** the light engine

The interfaces respect complementary value propositions of light engines and luminaire to open design opportunities and to maximize the economic advantages

- The control interface can specify the required dimming level, *not the dimming method*.
- The control interface can specify the required color, *not the method for achieving the color*.
- The photometric interface specifies surface area and the light output, *not the use of diffuser plates, remote phosphors etc. inside the light engine and not the use of lenses or reflectors in the luminaire*.



Enable alternative implementations

- Whenever practically possible, the Zhaga consortium will set interface standards that allow more than one implementation of the light engine
 - margins and tolerances should be broad
 - interface specifications should not imply a single technical solution
- This should prevent that only a single company can manufacture a Zhaga-compliant light engine



Interface between LED driver and Light Engine

- Zhaga will not standardize the interface between LED driver electronics and the light engine
 - This interface is rapidly evolving. It is not stable.
- Case 1: LED driver integrated in light engine
 - Typical for low power light engines
 - Interface between driver and engine is hidden
- Case 2: LED driver in separate box
 - Typical for high power light engines
 - Separate boxes with non-standard interface between the boxes
 - Other interfaces of driver may be standardized
 - Other interfaces of light engine may be standardized

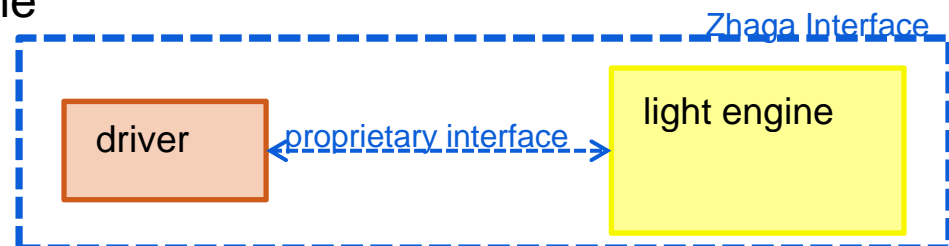
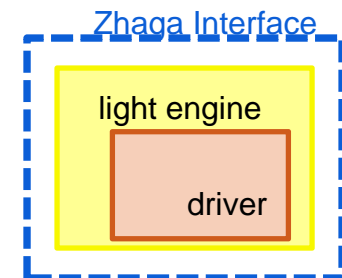



Certification, Compliance, Logo and Fees

- Zhaga will establish methods for certifying that:
 - LED light engines comply with the standard,
 - complementary components comply with the standard.
- Only certified products are allowed to carry the Zhaga logo and name of the standard
- Certification will be done by independent test labs
- Zhaga members pay an annual membership fee
 - Membership fees are used for the organization of meetings, publicity, promotion of the standard and to monitor certification
- Members participating in standardization activities carry their own costs (travel, salary cost, prototyping, measurements etc.)



Patents and royalties

- Royalty-free licenses for all patents that are necessary to implement the interface standards developed by the consortium.



Scope

- The Zhaga consortium will focus first on:
 - standards relevant to all regions worldwide,
 - standards for professional applications
 - shops, hospitality, outdoor
 - followed by offices and industry
 - applications that are out of reach for retrofit LED products
 - with strong need for new interfaces
 - with lumen output of at least 1000 lm
 - note that family extensions to lower lumen are allowed

